

# Intelligent Obstacle Avoidance Car DIY Kits

## 1. Introduction

Mainly through the motherboard about two photosensitive sensors to sense light. When the right light sensor detects light and the left is not detected, the car turns to the right; When two light sensors detect light at the same time, the car moves forward; When the attention of the source to move, when the left light sensor detects the light, the right is not detected, turn the car to the left; When the left and right sensors detect the light at the same time, the car moves forward and goes back. Cycle again and again.

## 3. Parameter

- 1>. Power: DC 6V
- 2>. Material: PCB
- 3>. Purpose: Car tracking, infrared obstacle avoidance car, car maze, object tracking function.

## 4. Feature

- 1>. Simple mechanical structure, easy to install.
- 2>. The two deceleration DC motors turn flexibly and have good

direction.

3>. Two motor drives, horsepower.

4>. The chassis is large and stable and easy to expand.

## 5. Function

1>. The range of infrared tracking module to realize intelligent tracking (go black or white)

2>. The two pairs of infrared reflections in front of the front can realize intelligent collision avoidance (obstacle avoidance) function and robot maze. The on-board obstacle avoidance processing chip makes the obstacle avoidance distance farther.

3>. The intelligent robot maze experiment was realized by two pairs of infrared reflection probes in front of the front.

4>. The intelligent robot object tracking function is realized by the two pairs of infrared reflection probes in front and right.

5>. The infrared receiving diode is changed to light sensitivity, which increases the daytime and night recognition function for the robot and can be used as a light finding robot. (search for light and infrared barrier can not be used simultaneously).

## 6. Component listing.

NO.	Component Name	PCB Marker	Parameter	QTY
<b>Controller PCB</b>				
1	Ceramic Capacitor	C2-C4,C7	0.1uf 104	4
2	Ceramic Capacitor	C8,C6	30pf	2
3	LED 3mm	D3,D5	Green	2
4	LED 3mm	D5	Red	1
5	L293D	IC1	DIP-16	1
6	IC Socket	IC1	DIP-16	1
7	STC89C52	IC2	DIP-40	1
8	IC Socket	IC2	DIP-40	1
9	Male Pin	P1-P3	4P	3
10	Metal Film Resistor	R2,R3	10K	2
11	Metal Film Resistor	R8,R14	1.5K	2
12	Network Resistor	RX1	10K	1
13	Button	S2	6*6*5mm	1
14	Crystal	Z1	12MHz	1
15	Controller PCB		43*65mm	1
<b>Chassis PCB</b>				
16	Electrolytic Capacitor	C1	10V 1000uF	1
17	LED 3mm	D1,D2	Green	2
18	Infrared Transmitter	V2,V4,V8,V9	3mm	4
19	Infrared Receiver	V3,V5,V6,V7	3mm	4
20	LM393	IC3	DIP-8	1
21	IC Socket	IC3	DIP-8	1
22	Metal Film Resistor	R6,R7,R10,R11	10K	4
23	Metal Film Resistor	R12,R13,R15	220ohm	3
24	Metal Film Resistor	R16,R18	15K	2
25	Switch	S1		1
26	Potentiometer	W1,W2	10K	2
27	Jumper Cable		By Component's Pin	
28	Male Pin	P5,P7	3P	2
29	Main PCB		77*170mm	1
<b>Machinery Parts</b>				
30	Motor			2
31	Battery Box		AA*4	2
32	Cable		7cm	2
33	Non-slip ring			2
34	Wheel		40mm	4
35	Axle		2*120mm	1
36	Motor Fixed seat			6
37	M3 Nut			7
38	M3*8mm Screw			3
39	M3*25mm Screw			4

40	Heat shrink tube		5cm	1
41	Motor Fixed Screw			2
42	Loader			1
43	Motor Cable			4

## 7.Installation Steps

Step 1: Install Controller.Install 2pcs 10K resistor,2pcs 1.5K resistor,1pcs Crystal,2pcs 30pf capacitor,4pcs 0.1uf capacitor and 1pcs button

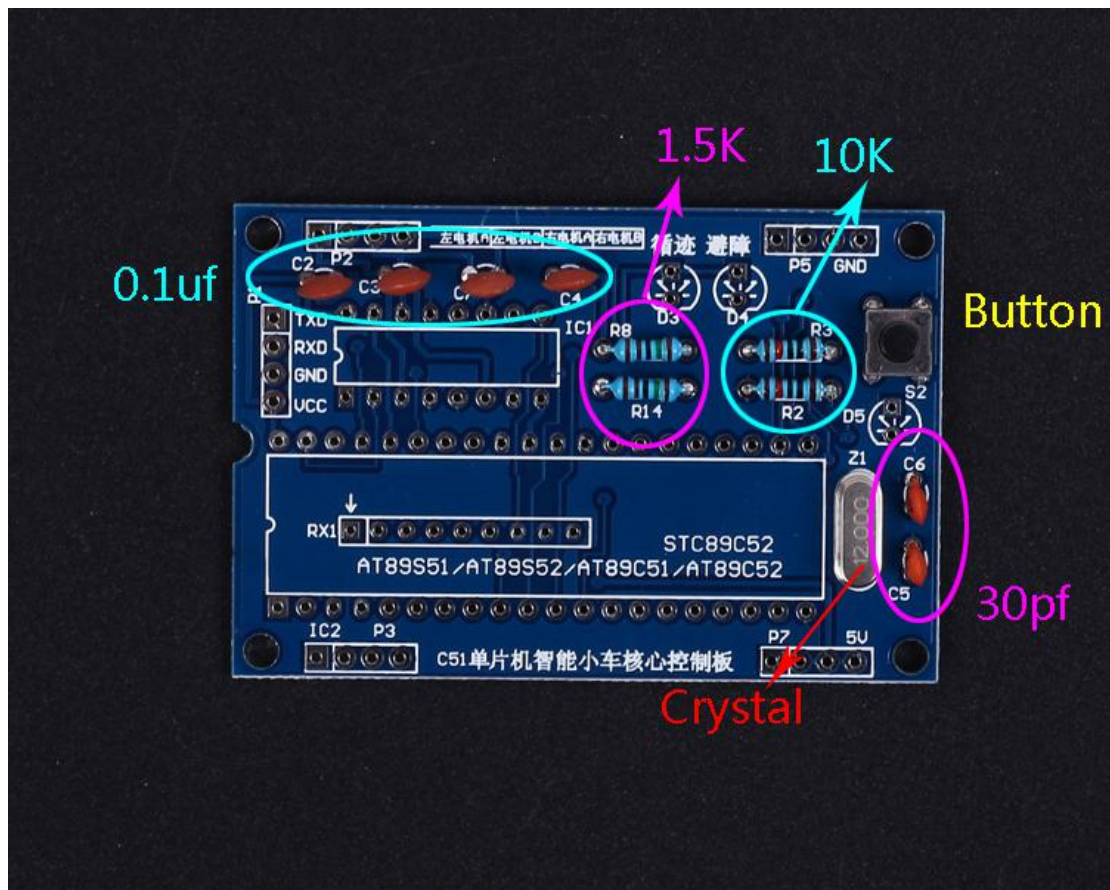

Step 2: Install 3pcs 3mm LED,2pcs IC socket,1pcs network resistor.Please pay attention to the installation direction for all this components!!

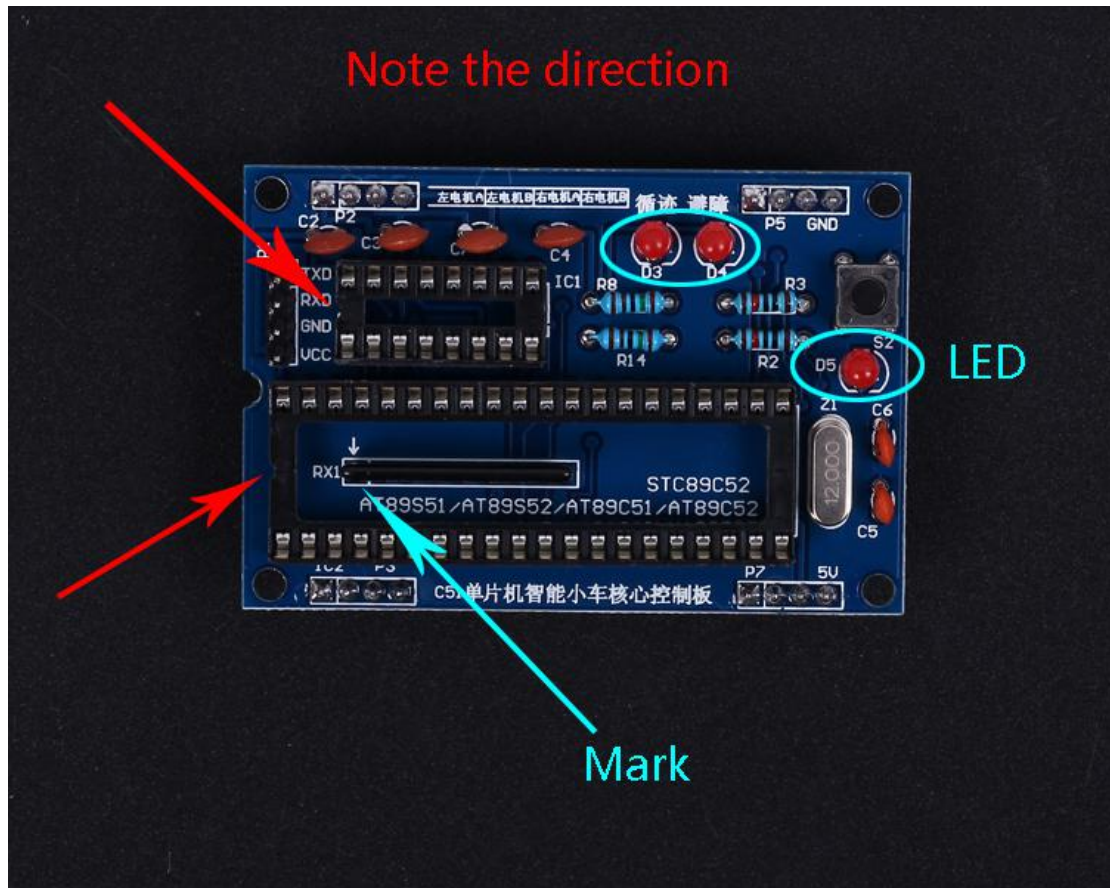

Step 3: Install UART interface and fixed pins. Note that the pins are not installed in the same side of PCB!

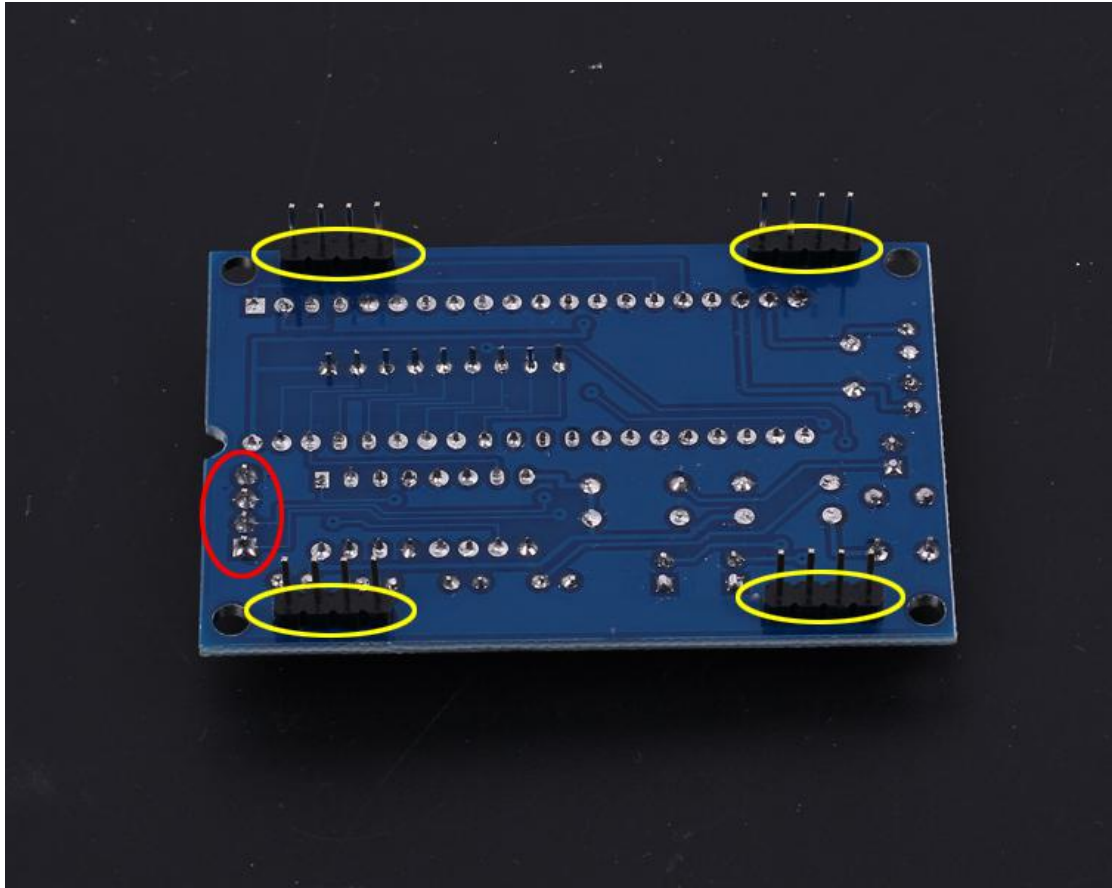

Step 4: Install IC.

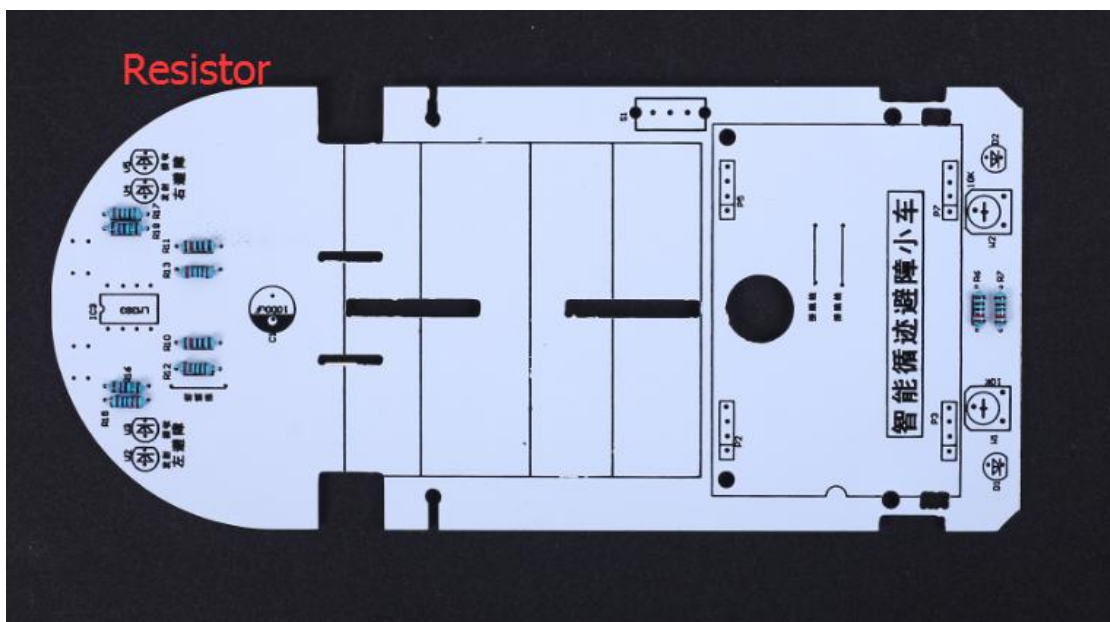
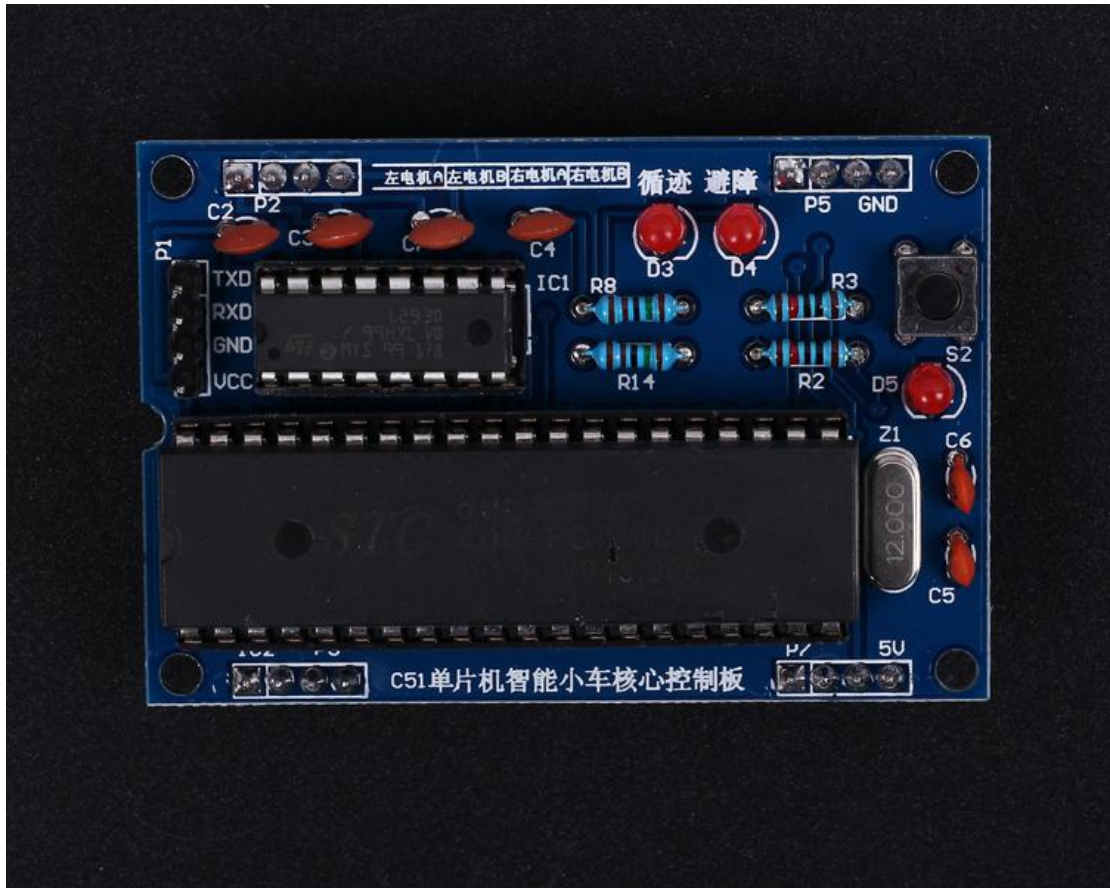

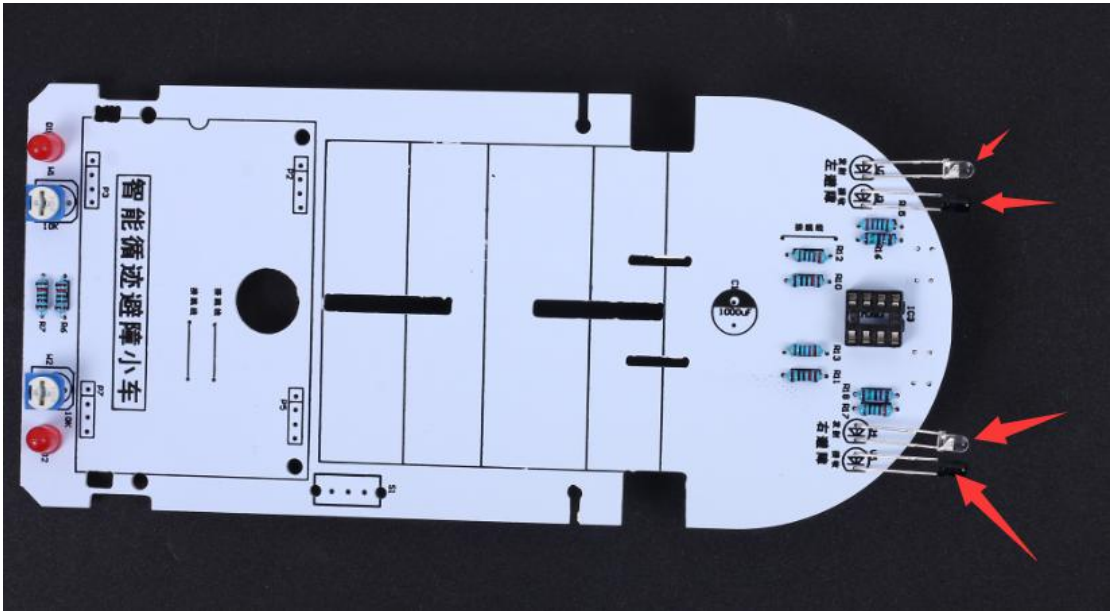
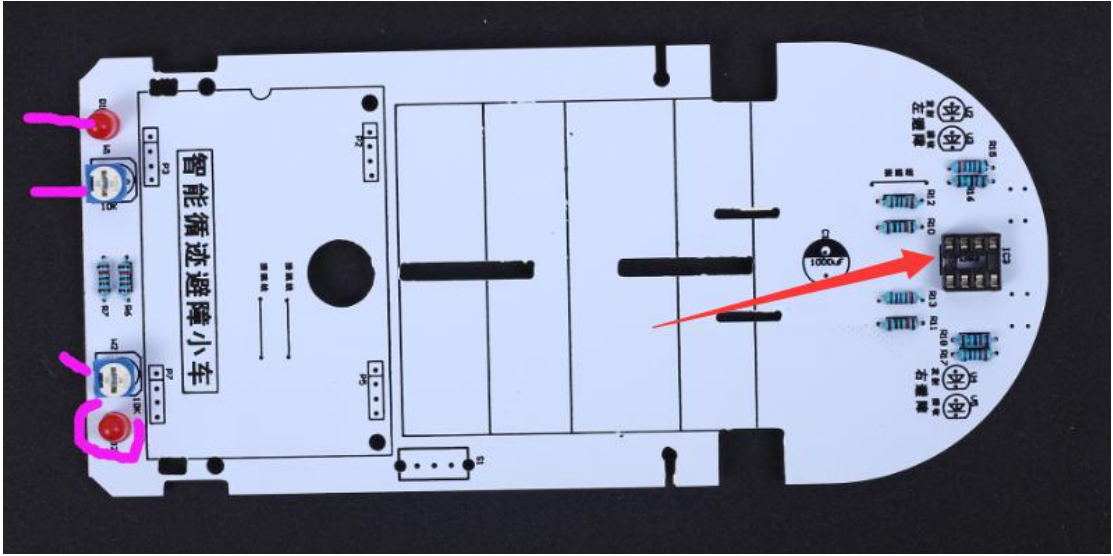



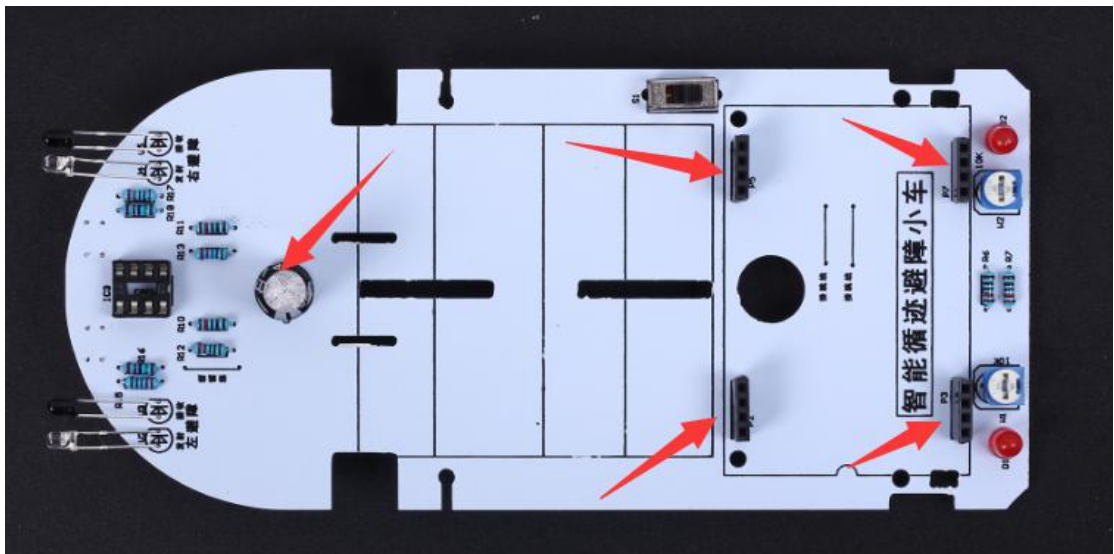
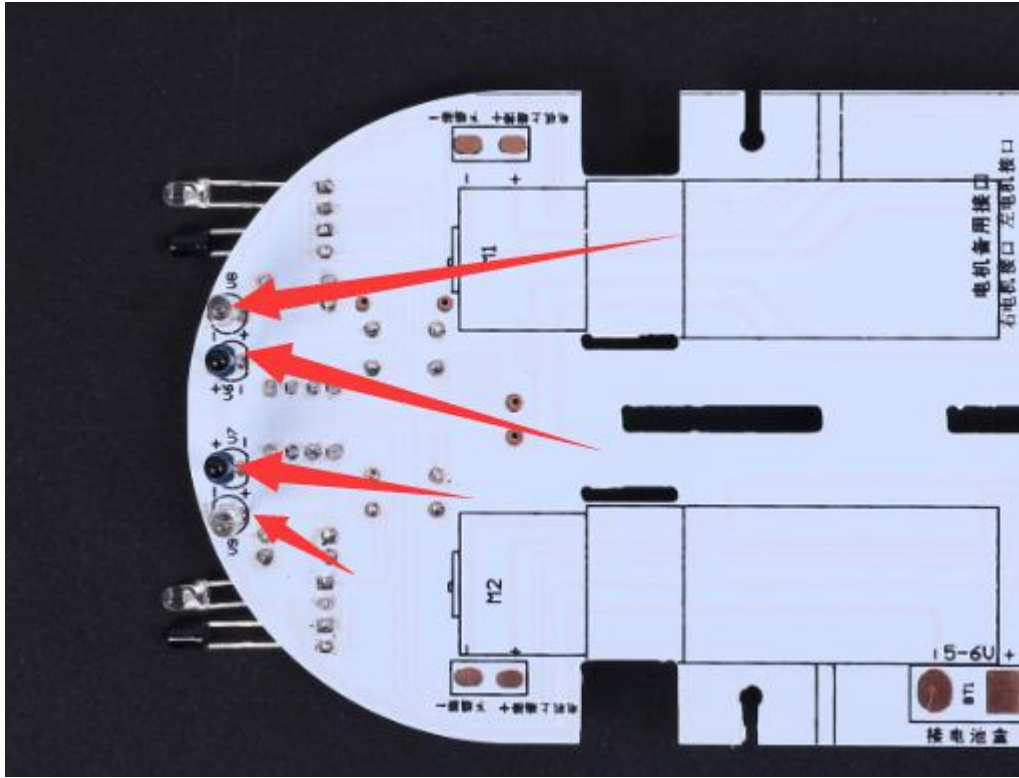

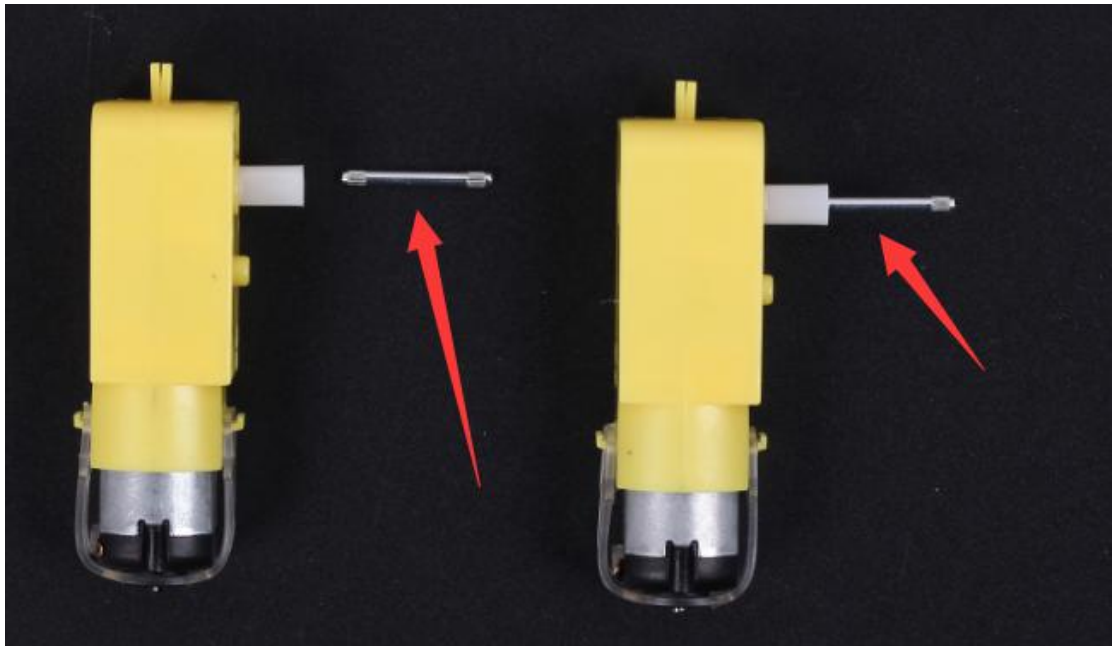
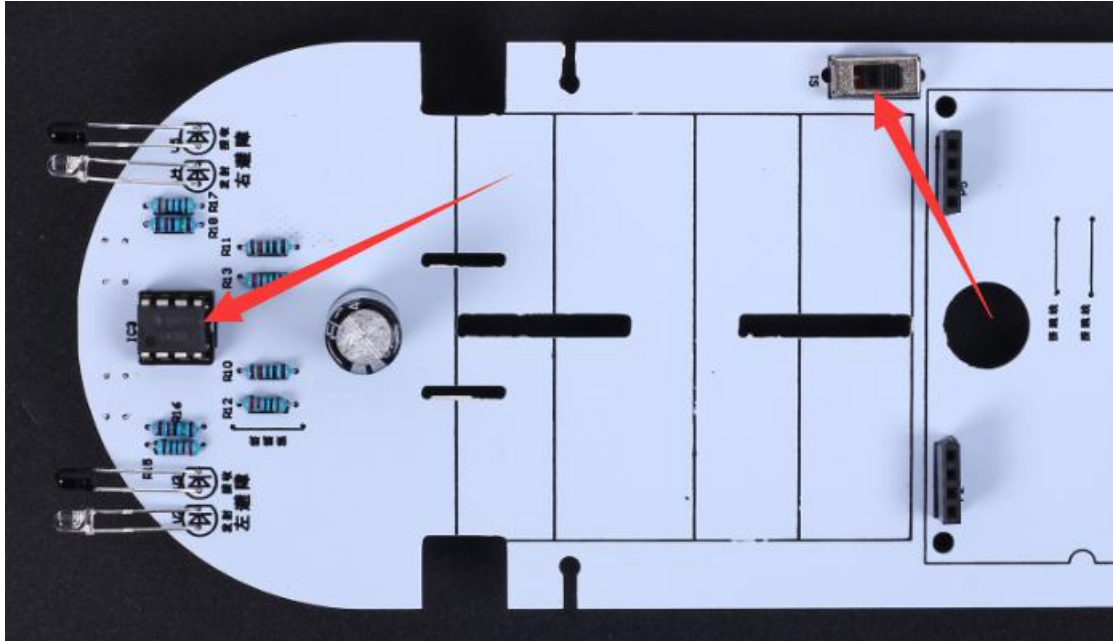

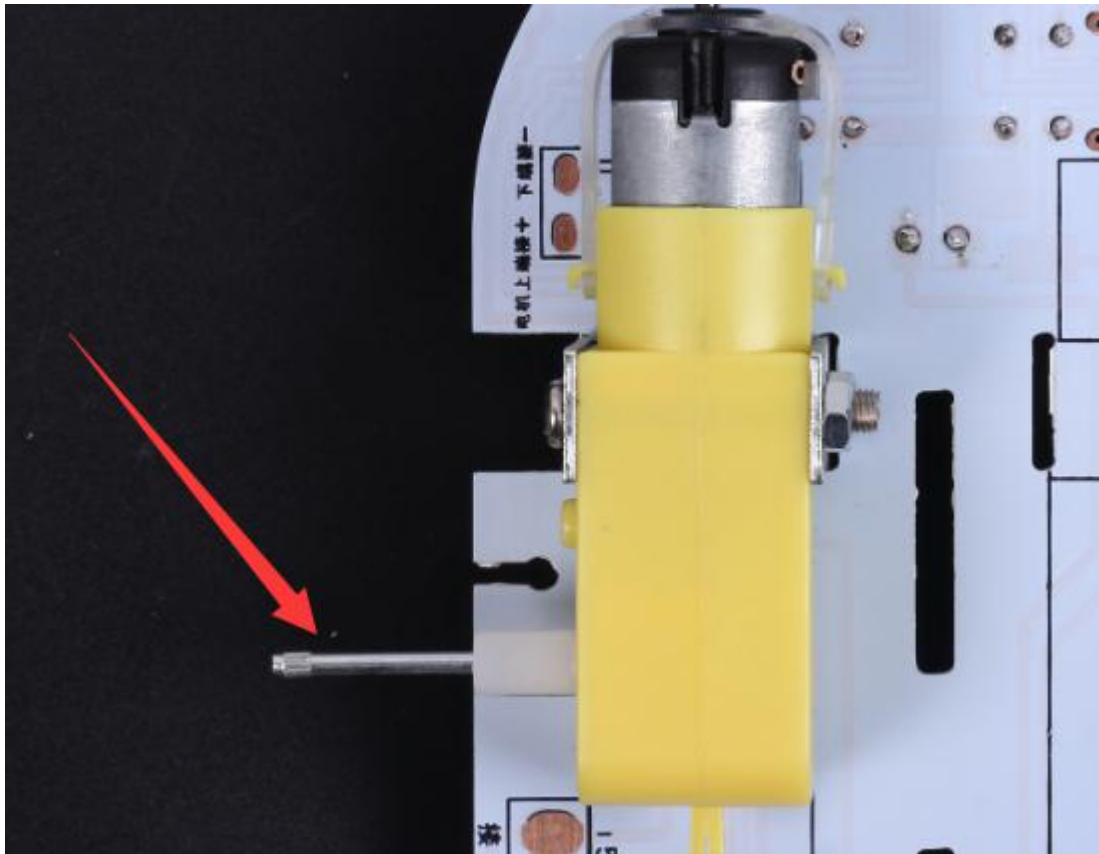
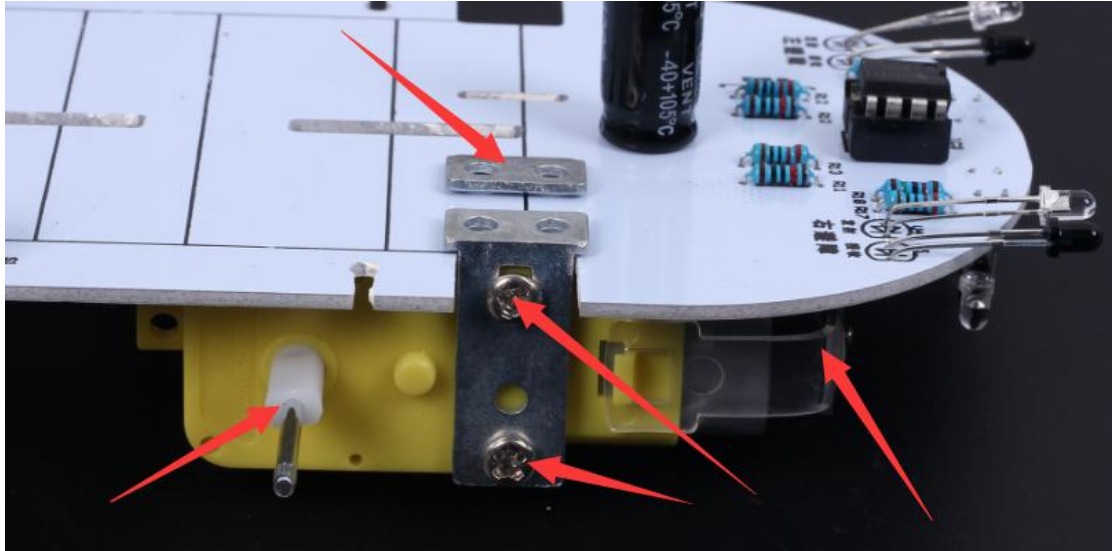

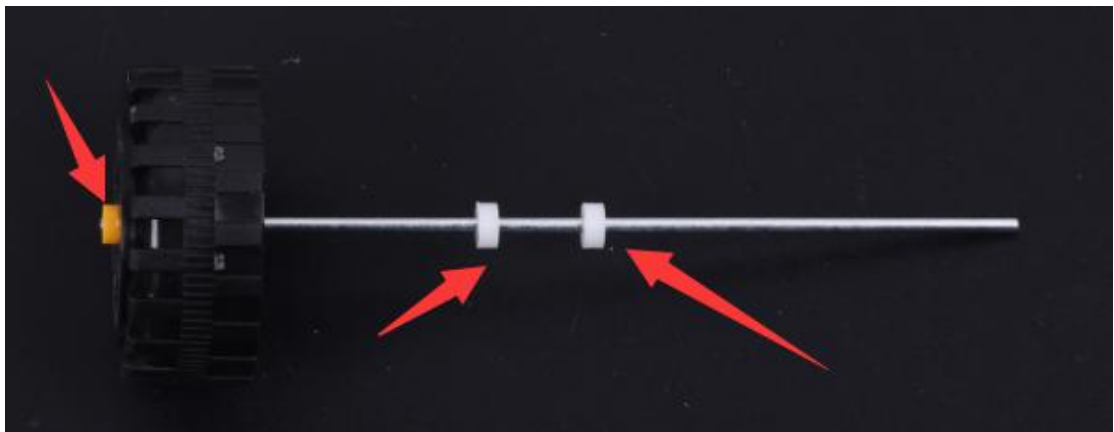
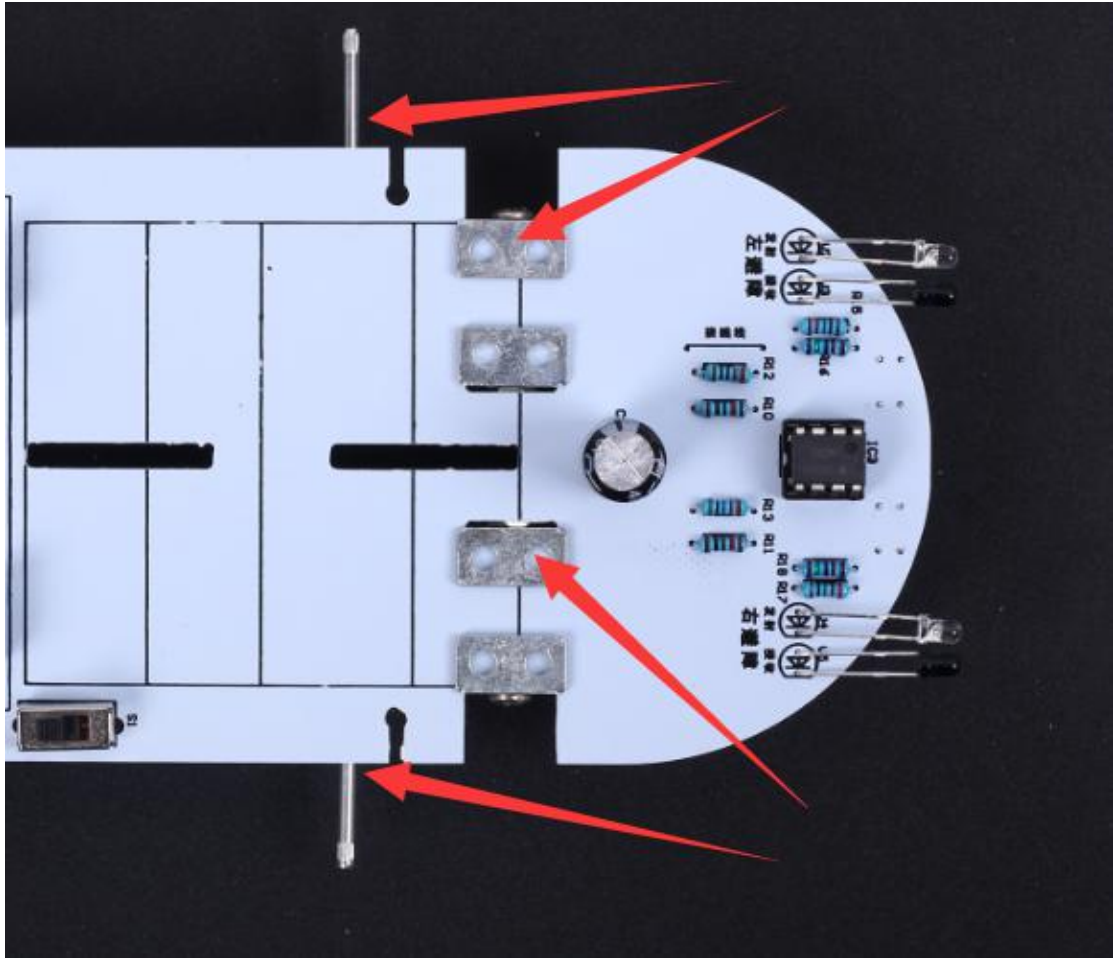

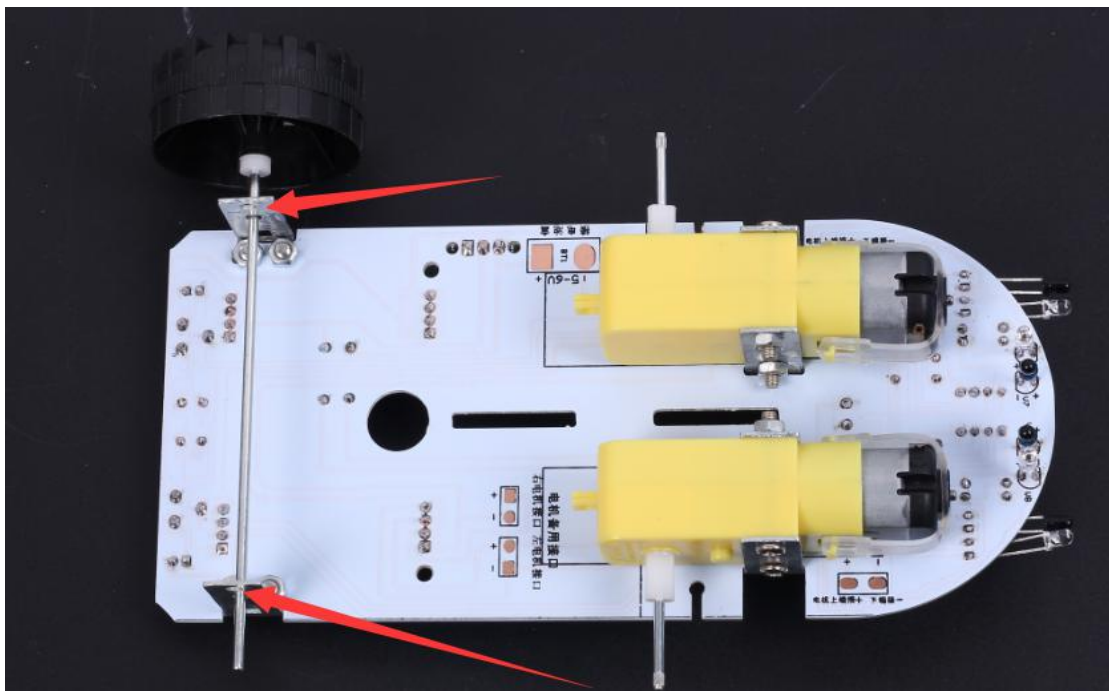
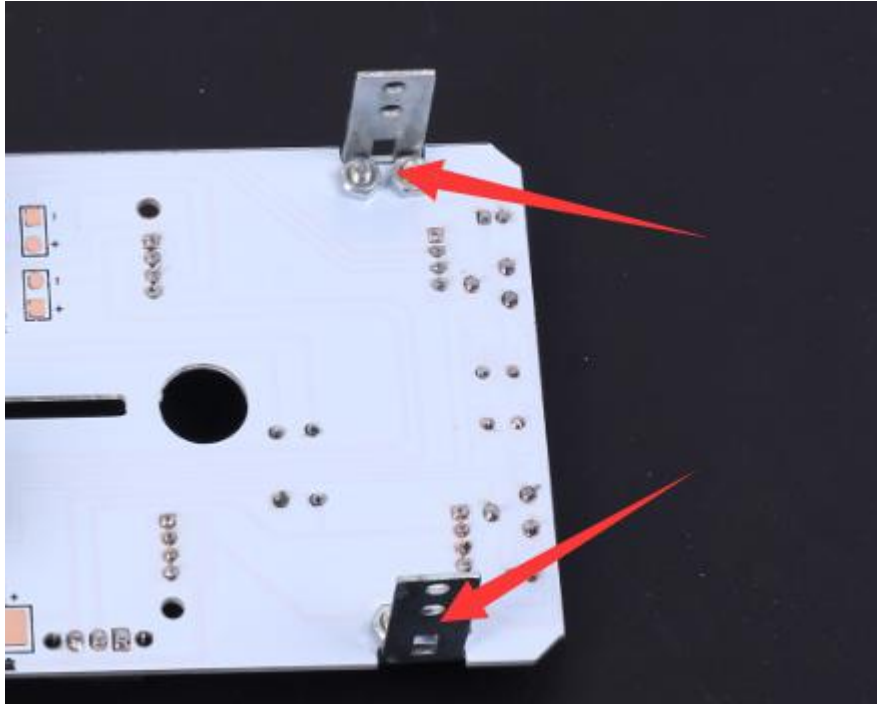



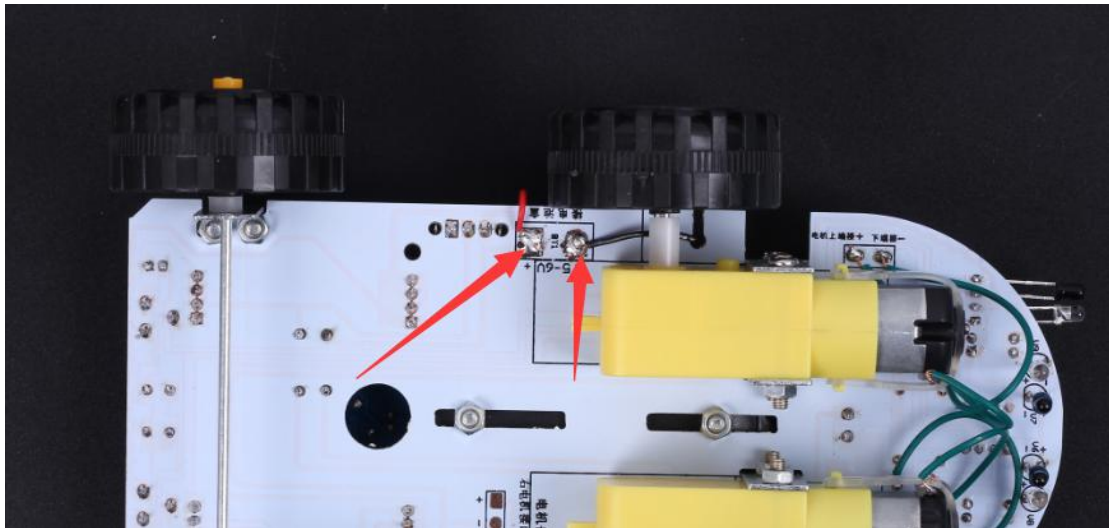
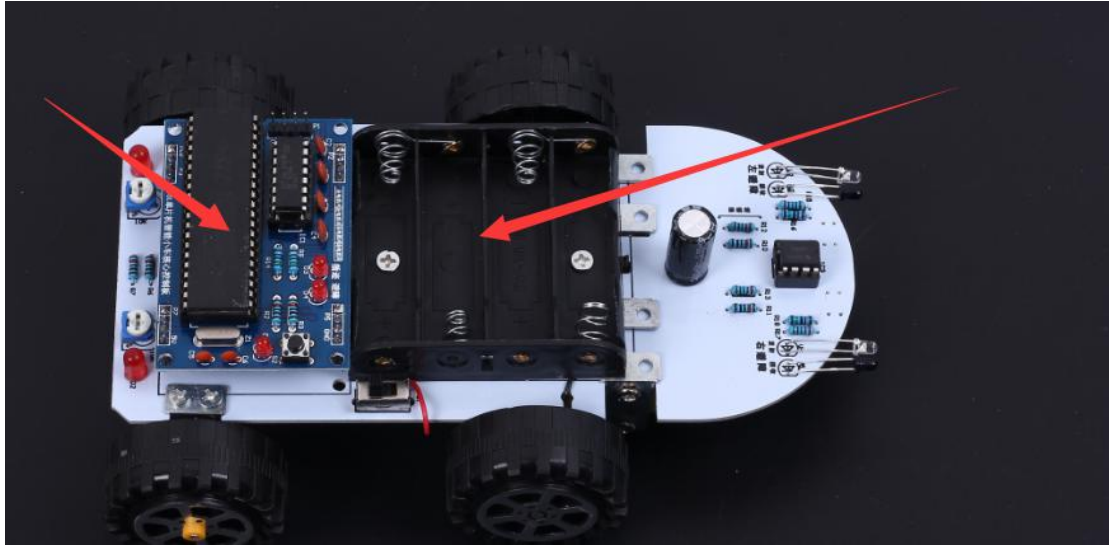

## 8.Effect demonstration

